

面積式流量計

FC-SD Flow checker



- 耐久性に優れています。
- 流れ方向の制約を受けません。
- 全機種センサ取付可能です。
- 耐圧・耐熱に優れています。
- Excellent in durability
- No restriction on flow direction
- Alarm switch can be installed to all types.
- Excellent in pressure / heat resistance

型式 Model number selection

規格 Std.	接続 Connection	警報 Alarm	流れ方向 Flow direction	流体名 Fluids	流量単位 Units	最大流量 Max. flow	材質 Material	接続口径 Connection size	オプション Option	特殊項目 For specialized item
FC-SD										

FKM	バイトンパッキン	Viton packing
D	防滴タイプ	Drip-proof type *1
VP	高圧仕様:Max. 2MPa(G)	High pressure spec.: Max. 2MPa(G)*1*5
WP	高圧仕様:Max. 7.5MPa(G)	High pressure spec.: Max. 7.5MPa(G)*1*5
VT	耐熱仕様:Max. 150℃	Heat resistant spec.: Max. 150℃ *1
WT	耐熱仕様:Max. 200℃	Heat resistant spec.: Max. 200℃ *1
W	溶接仕様:Max. 270℃	Welding specification: Max. 270℃ *1

	Rc	JIS 10KF
01	1/4	—
02	3/8	10A
03	1/2	15A
04	3/4	20A
05	1	25A
06	1 1/4	32A
07	1 1/2	40A
08	2	50A
09	2 1/2	65A
10	—	80A
11	—	100A

BS	BSBM(メッキ)	(Plating) Ni-3 *1
304	SUS304	

Max. 次ページ、測定範囲の最大流量を記入 Max. flow rate selected from the available flow range next page

B	L/min	
Z	特殊 For specialized unit *2	
1	水 Water	
9	特殊 For specialized fluid *2	
R	左→右 Left→Right	
L	右→左 Right→Left	
U	下→上 Down→Up	
D	上→下 Up→Down *4	
0	スイッチ無し With no switch	
1	リードスイッチA接点 With reed switch contact A *3	
2	リードスイッチB接点 With reed switch contact B *3	
9	特殊 For specialized alarm *2	
無記入 Blank	Rc接続 Rc connection	
F	フランジ接続 Flange connection	
規格 Std.	規格最大流量 Max. flowrate specified	接続口径 Connection size
65 *1	~5L/min	Rc1/4~1/2
70 *1	~50L/min	Rc1/4~1, JIS10K 10~20A
85	~100L/min	Rc3/4~1 1/4, JIS10K 20~32A
85L	~250L/min	Rc1 1/2~2, JIS10K 40~50A
130	~700L/min	Rc2 1/2, JIS10K 65~80A
130L	~1000L/min	JIS10K 80~100A

- *1: 対応できない仕様があります。次ページの対応表を参照願います。
- *2: 特殊項目に付いては、型式末尾に順番に明記下さい。詳細は当社にお問合せ下さい。
- *3: A接点: 設定値以上クローズ、B接点: 設定値以下クローズ
- *4: D、流れ方向 上→下は、条件付で制作可。(配管上満水である事)
- *5: 高圧仕様を選択した場合は記号の後に使用圧力を明記下さい。
- *1: Some specifications are not available. Refer to "Table of flow ranges, flow direction, connection size and corresponding materials" on the next page for detail.
- *2: For specialized items specify them at end of Model number selection in order. For details, consult us with your specification.
- *3: Contact A: Switch is closed as the float rises past the switch. Contact B: Switch is closed as the float falls past the switch.
- *4: Flow direction D (to flow top to bottom) is conditionally made (Pipe must be filled fully with water).
- *5: When selected the high pressure spec., specify the operating pressure after the symbol.

流量および流れ方向、接続口径、材質対応表 Table of flow ranges, flow direction, connection size and corresponding materials

規格 Std.	測定範囲 Measuring range (L/min)	流れ方向 Flow direction	材質 Material																備考 Remarks																																			
			Rc								フランジ Flange																																											
			接続口径 Connection size	標準 Std. *1	D	VP	WP	VT	VP+VT	WT	W	接続口径 Connection size	標準 Std. *1	D	VP	WP	VT	VP+VT		WT *2	W *3																																	
65	0.1~1	左右のみ To right and left only	1/4	SUS		SUS				SUS										浮遊式 Floating type 流れ方向 Flow direction 																																		
	0.2~2		3/8	304	-	304	-			SUS																																												
	0.4~5		1/2																																																			
70	0.1~1	下→上のみ Bottom to top only	1/4	BSBM/ SUS304						SUS304									10A	浮遊式 Floating type																																		
	0.2~2		3/8																																																			
	0.4~5		1/2																																																			
	1~10	全て対応 Correspond to all directions of flow	3/4																																																			
	1~15		1																																																			
	2~20		1																																																			
	2~30		1																																																			
4~50		3/4																																																				
85	4~50	全て対応 Correspond to all directions of flow	1	SUS304						SUS304									20A	浮遊式 Floating type																																		
	5~70		1																																																			
	10~100		1 1/4																																																			
85L	10~150		全て対応 Correspond to all directions of flow																1 1/2		SUS304						SUS304									40A	浮遊式 Floating type																	
	20~200																		2																																			
	50~250																		2																																			
130	30~200																		全て対応 Correspond to all directions of flow																	2 1/2		SUS304						SUS304									65A	浮遊式 Floating type
	40~300																																																					
	60~500																																																					
	100~700																																																					
130L	200~1000	全て対応 Correspond to all directions of flow		SUS304						SUS304										80A	浮遊式 Floating type																																	
			全て対応 Correspond to all directions of flow																			SUS304						SUS304																										

*1: オプションのVT、WT、Wタイプ対応不可

*2: スイッチ付はRcネジのみ対応可

*3: フランジタイプの溶接仕様は、特注になります。

*測定範囲は水換算 20℃(293K)条件の流量です。

*スイッチ設定範囲は、F.S.流量の約20~80%が使用範囲です。ただし、個々の目盛や接点方式等により使用範囲は異なります。

*1: Optional specifications of VT, WT and W types are not available.

*2: The type with switch is only for Rc threaded connection.

*3: Welding specification on the flanged type is for special order.

*Measuring range shown above are ones equivalent to water at 20°C.

*Set point for contact range shall be within 20% - 80% of F.S. However, it varies depending on a scale and contact method of flowmeter.

仕様 Specifications

規格 Std.	標準 Std.	VP	WP	VT	WT	W
流量精度 Flow accuracy	±5% of F.S.					
使用最高圧力 Max. operating pressure	1.0MPa(G)	2MPa(G)	7.5MPa(G)	0.75MPa(G)	0.75MPa(G)	0.75MPa(G) *1
使用流体温度 Operating fluid temperature	Max. 80°C	Max. 80°C	Max. 80°C	Max. 150°C	Max. 200°C	Max. 270°C
使用環境温度 Ambient temperature	0~60°C (結露なきこと No dewing)					
接点方法 Contact forms	A接点：設定値以上クローズ Contact A: Switch is closed as the float rises past the switch. B接点：設定値以下クローズ Contact B: Switch is closed as the float falls past the switch.					
接点容量 Contact capacity	DC 0~24V 0-24VDC Max. 0.2A					
ケーブル長 Cable length	2m (AWG 19)					
パッキン Packing	NBR		NBR *2	FKM	NEW PF	—

*1: 20MPa(G)まで対応可。ご相談下さい。

*2: Oリングにバックアップリング付。

*1: Available for Rc thread type up to 20MPa(G). Consult us with your specifications.

*2: O-ring provided with backup ring.

構造図 Structural drawing

※ 規格寸法と材質につきましては、右ページをご参照ください。

FC-SD65 浮遊式/スイッチ付
Floating type with switch

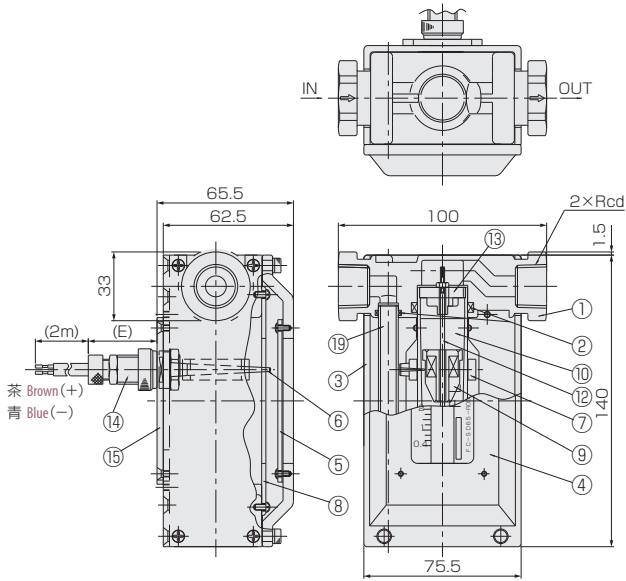

FC-SD 標準/スイッチ付
Flow indicating type with switch

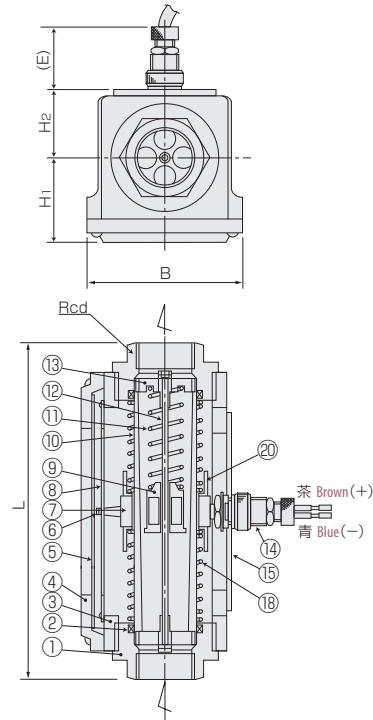

FC-SD 浮遊式タイプ
Floating type

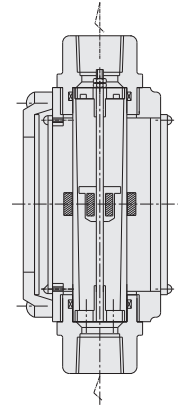

*必ず垂直に配管してください。
* Be sure to make up pipe vertically

FC-SD フランジタイプ
Flanged type

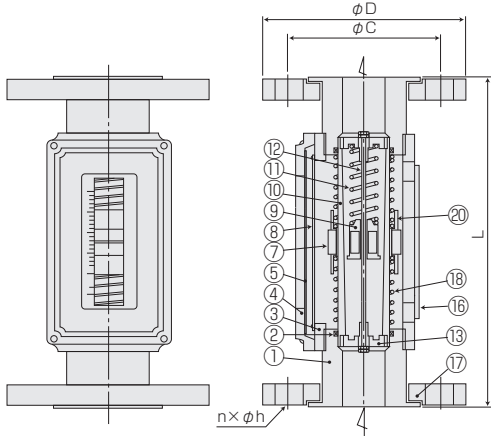

*フランジはルーズフランジ形状になります。 * Flanges are used in shape of loose flange.

特殊型参考図 Referential drawing for specific types

防滴タイプ Drip-proofing type

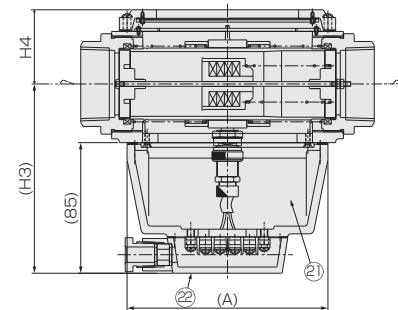

*窓枠、防滴ケース、端子ケース、フロントプレート、フィッティング端面には防水パッキングが装着されています。
* Packing for water proofing are put into window frame drip-proof case, terminal case, front plate and end face of the fitting.

VT仕様タイプ High-temperature spec. of VT type

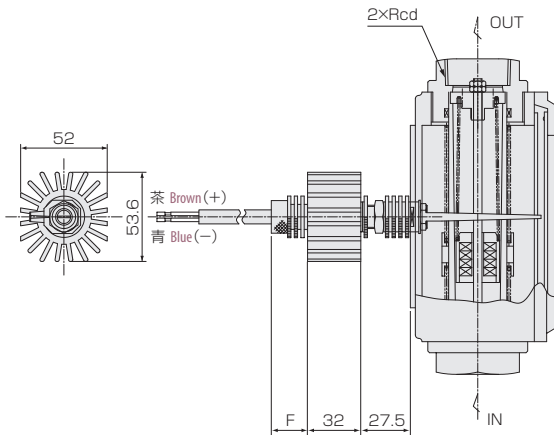

WT仕様タイプ High-temperature spec. of WT type

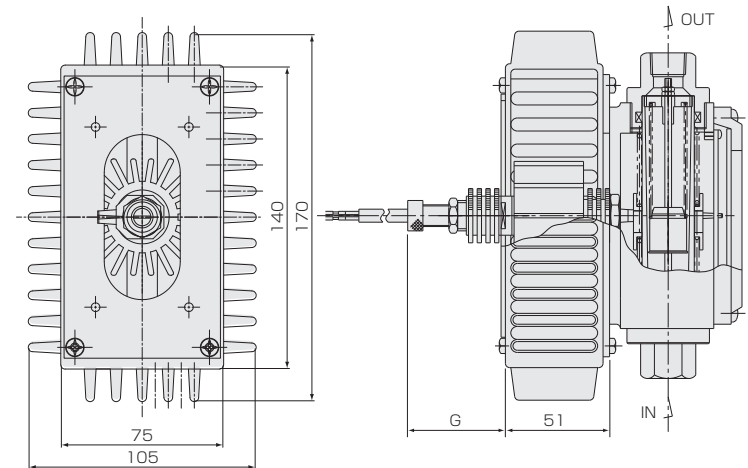

* センサヘッドに風をあてて周囲温度を60℃程度まで下げて下さい。 * Lower the ambient temperature up to such degree of 60°C by exposing sensor head to wind.

規格寸法 Standard dimensions

規格 Std.	Rc			フランジ Flange							A	B	H1	H2	H3	H4	E	F	G
	L		d	L			接続口径 Pipe size	φC	φD	n×φh									
	標準 Std.	W		標準 Std.	VP	W													
65	構造図参照 Refer to structural drawing	—	1/4 3/8 1/2	—							構造図参照 Refer to structural drawing						35	29.5	41
70	150	150	1/4 3/8 1/2 3/4 1	180	180	190	10A 15A 20A	65 70 75	90 95 100	4×15 4×15 4×15	90	70	34	30 (29)	112	35	35	29.5	41
85	190	190	3/4 1 1 1/4	230	230	250	20A 25A 32A	75 90 100	100 125 135	4×15 4×19 4×19	130	85	47	41 (40)	123	48	45	39.5	54
85L	190	260	1 1/2	230	230	250	40A 50A	105 120	140 155	4×19 4×19	130	85	47	41 (40)	123	48	50	44.5	59
	210		2																
130	230	300	2 1/2	230	300	300	65A 80A	140 150	175 185	4×19 8×19	130	130	74	78 (77)	160	75	35	29.5	44
130L	—			230	300	300	80A 100A	150 175	185 210	8×19 8×19	130	130	74	78 (77)	160	75	35	29.5	44

()寸法は、スイッチ無し寸法になります。Dimensions in the parenthesis () are applied for a product with no switching capability.

材質 Materials

No.	名称 Names of parts	標準 Std./VP/WP *1	VT	WT	W
1	フィッティング Fitting	BSBM/SUS304		SUS304	
2	Oリング O-ring *1	NBR	FKM	NEW PF	—
3	ケース Case	Al(合金) Al alloy			
4	フロントフレーム Front frame	Al(合金) Al alloy			
5	フロントプレート Front plate	PC	耐熱ガラス Heat-resistant glass		
6	ポインター Pointer	燐青銅 Phosphor bronze			
7	インジケータ Indicator	フェライト Ferrite			
8	スケールプレート Scale plate	ベークライト Bakelite		Al	
9	フロート Float	SUS304(Mg密封) (Mg sealed)			
10	テーパ管 Tapered tube	BSBM/SUS304	SUS304		
11	スプリング Spring	SUS304			
12	ガイドポール Guiding pole	SUS316			
13	ストッパー Stopper	BSBM/SCS14	SCS14		
14	リードスイッチ Reed switch	BSBM他 BSBM, etc. (AWG 19)			
15	スイッチプレート Switch plate	Al(合金) Al alloy			
16	バックプレート Back plate	PMMA	PTFE	Al	
17	フランジ Flange	SUS304			
18	サポートスプリング Supporting spring	SUS316			
19	パイプ Pipe	SUS304			
20	サポートリング Supporting ring	PE	PTFE	Al	
21	防滴ケース Drip-proof case	Al合金 Al alloy		—	
22	端子カバー Terminal cover	Al合金 Al alloy		—	

*1 WP高圧仕様にはOリングにバックアップリング(PTFE)が付きまます。 *1 For optional WP specifications, backup ring is attached to o-ring (PTFE).